

# ICOM IC-746 and IC-756 Series Transceivers Interconnection Diagram with Optional Receive and Transmit Audio Connections.

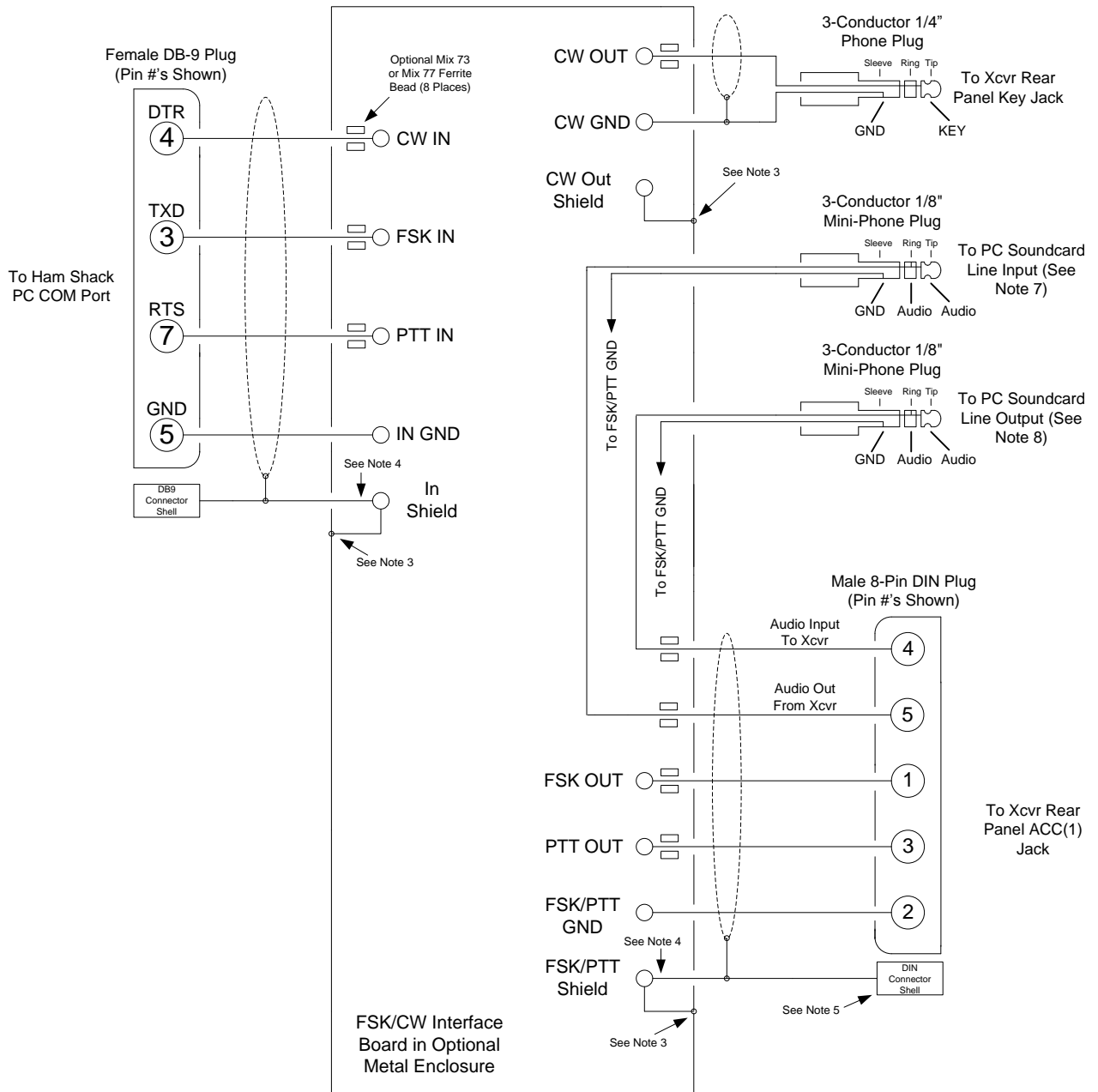

**Notes:**

1. The connections shown above are based on available documentation but have not been verified. Please review and use your own judgment before making any connections.
2. Make sure the transceiver RTTY settings are set for normal polarity and 170Hz shift. You may set any desirable mark frequency that is available in both the transceiver and MMTTY or other RTTY software you are using. **IMPORTANT:** Make sure that both your transceiver and RTTY software are set to the same mark frequency.
3. This connection made by mounting the board with metal standoffs or connecting the interface board mounting hole to the metal interface enclosure. You may also ground shields directly to the metal enclosure, if desired.
4. This connection optional. You may float the shield at the interface by leaving it disconnected and insulated from the metal interface board enclosure.
5. If the cable used with the DIN connector is shielded, you may optionally connect the shield to the DIN connector metal shell. This will ground the shield to the transceiver chassis.
6. RTTY and contest software, e.g., N1MM, WRITELOG, etc., must be configured for FSK, not AFSK, RTTY operation. Refer to the software documentation for instructions.
7. For receiving with external RTTY software, e.g. MMTTY, MixW, etc, receive audio must be provided to the line-level input of the PC soundcard. Fixed level receive audio, independent of the AF gain control setting, is available from Pin 5 (AF) and Pin 2 (Ground) of the ACC(1) jack as shown above. This receive audio will support not only RTTY operation, but PSK and other SSB digital modes. This connection is optional if you only use the transceiver's internal RTTY decoder or have another connection that provides receive audio to the PC.
8. Transmit audio for PSK and other SSB digital modes can be provided by connecting the line output of your PC soundcard to Pin 4 (MOD) and Pin 2 (Ground) of the ACC(1) jack, as shown above. This connection is optional and is not required for FSK or CW transmission.